

# DIA4RE

2.5 m<sup>3</sup>/h - 1% - 4%  
11 GPM - 1:100 - 1:25  
0.15 - 4 bar  
2.2 - 57 psi

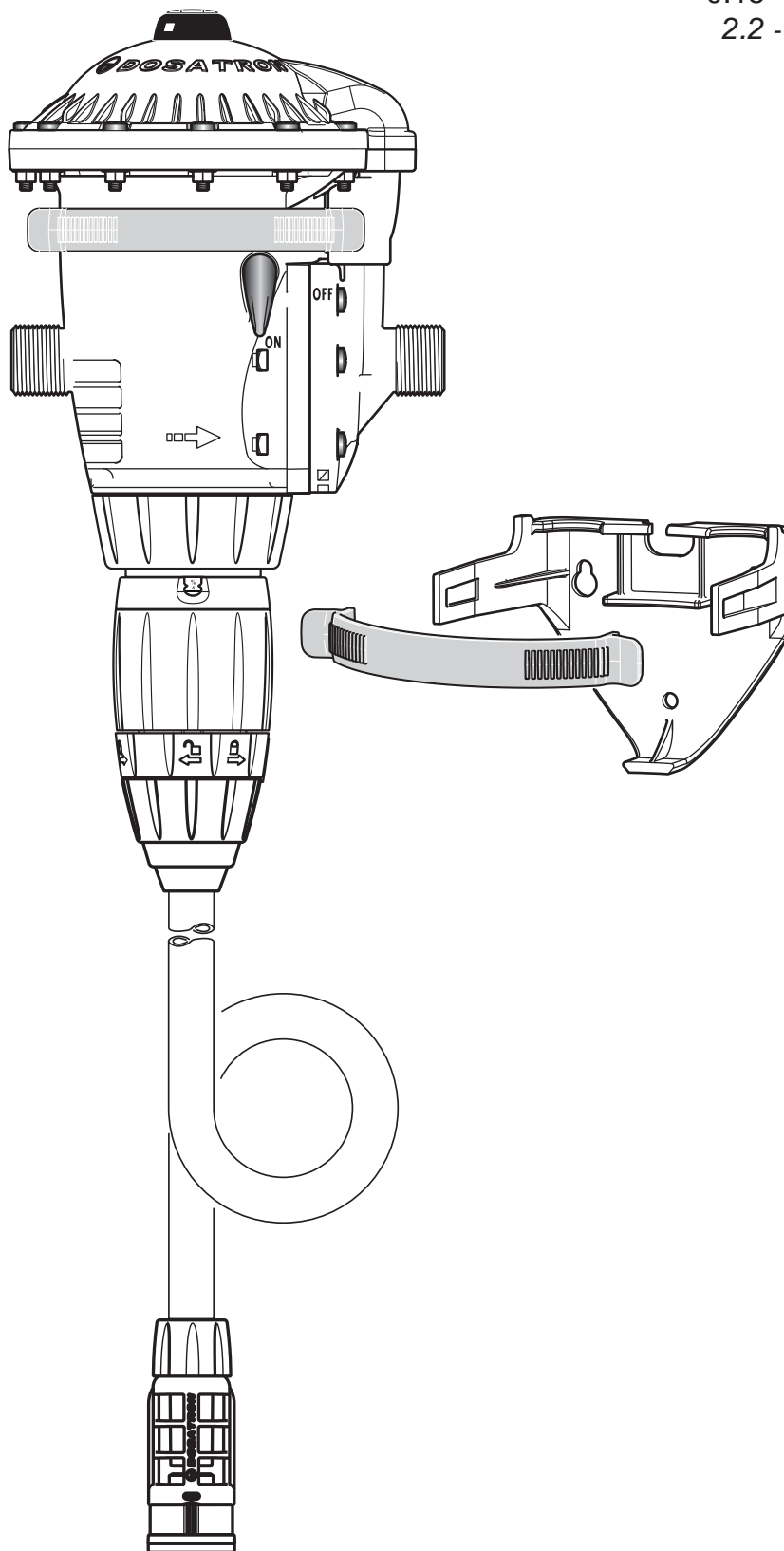

# DIA4RE

2.5 m<sup>3</sup>/h - 1% - 4%  
11 GPM - 1:100 - 1:25  
0.15 - 4 bar  
2.2 - 57 psi

**C+M**

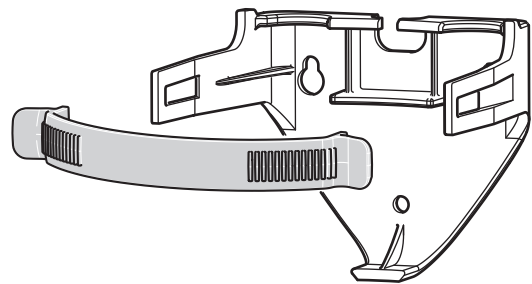
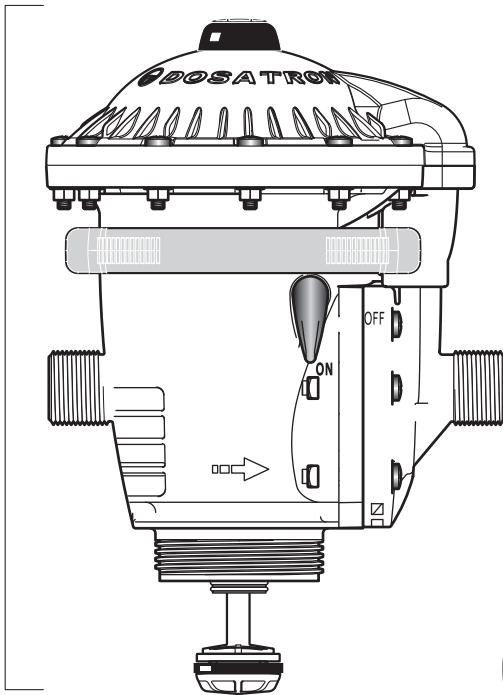

**D**

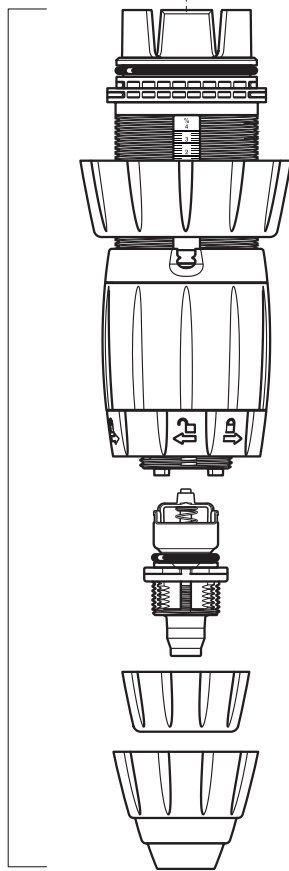

**A**

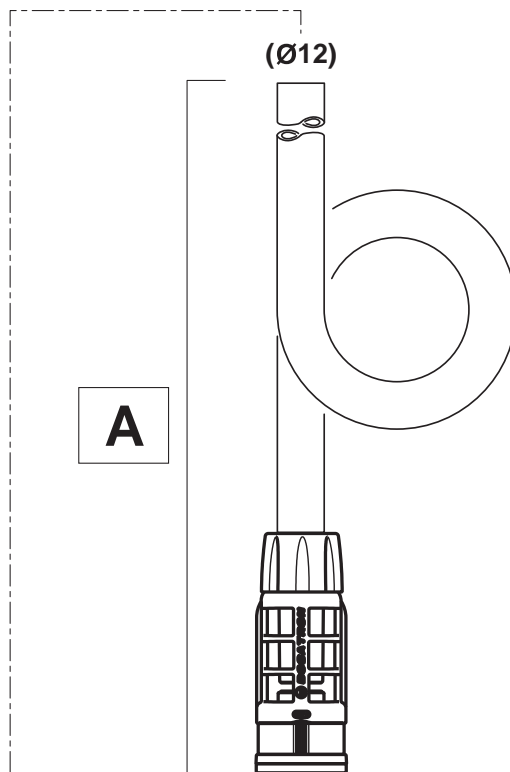

# DIA4RE

2.5 m<sup>3</sup>/h - 1% - 4%  
11 GPM - 1:100 - 1:25  
0.15 - 4 bar  
2.2 - 57 psi

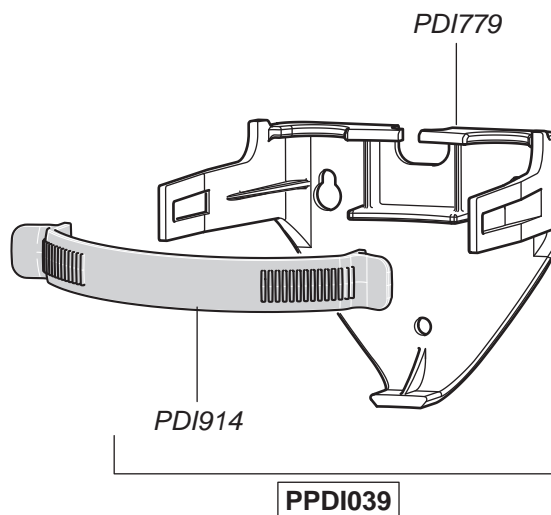
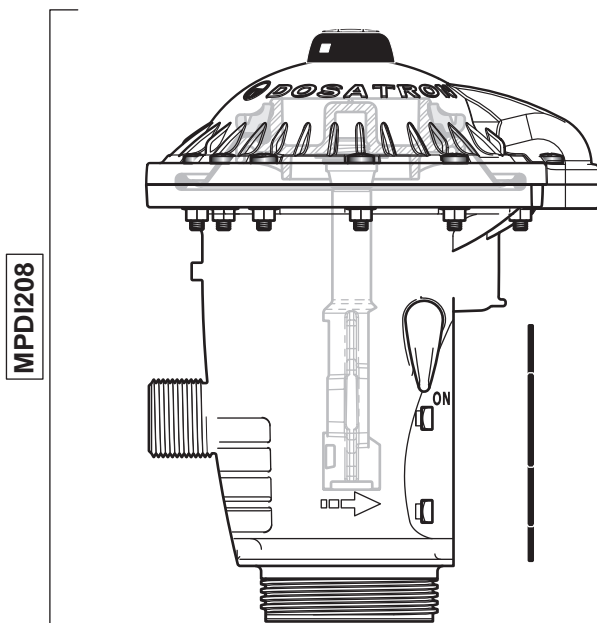

# DIA4RE

2.5 m<sup>3</sup>/h - 1% - 4%  
 11 GPM - 1:100 - 1:25  
 0.15 - 4 bar  
 2.2 - 57 psi

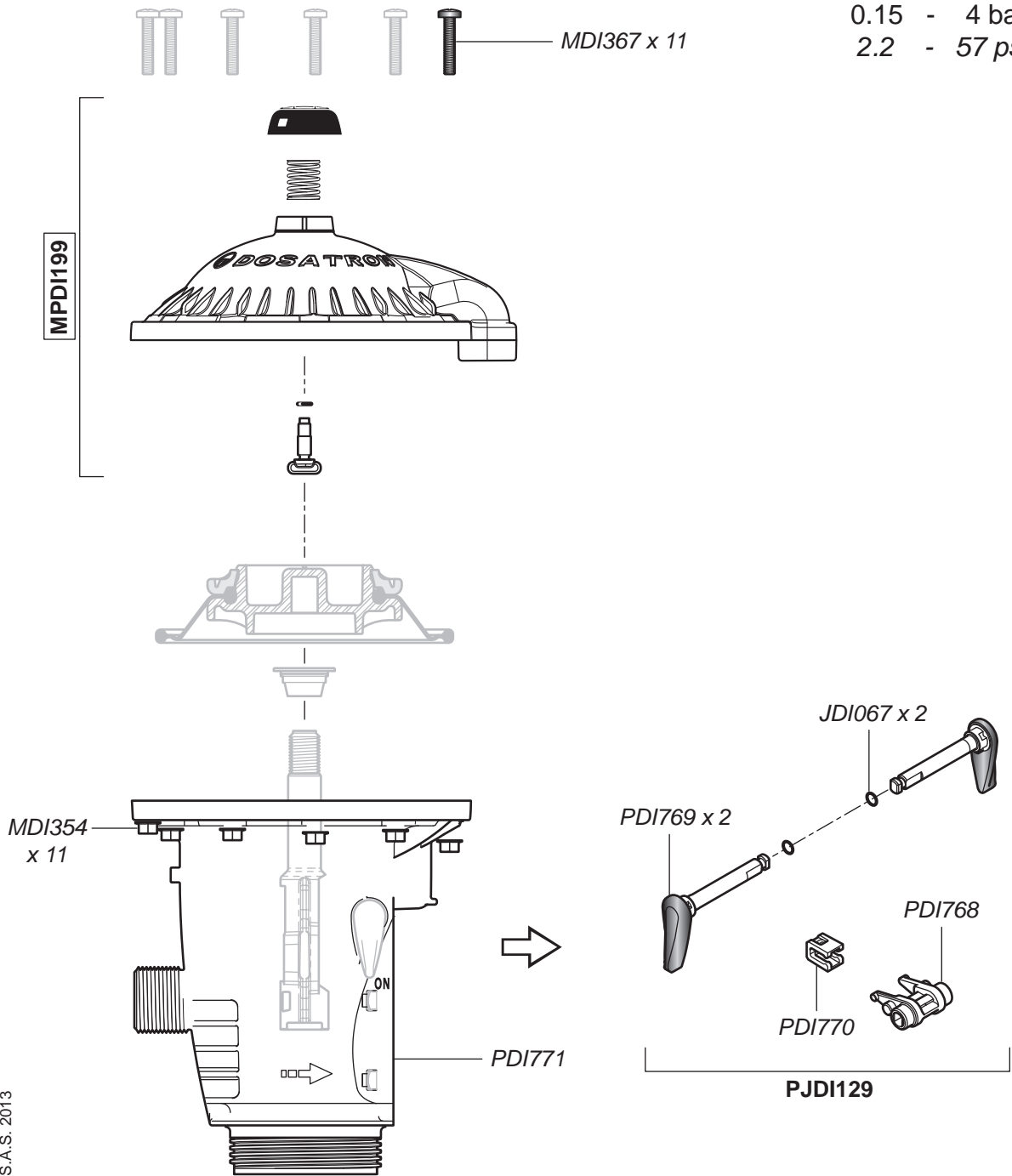

# DIA4RE

2.5 m<sup>3</sup>/h - 1% - 4%  
11 GPM - 1:100 - 1:25  
0.15 - 4 bar  
2.2 - 57 psi

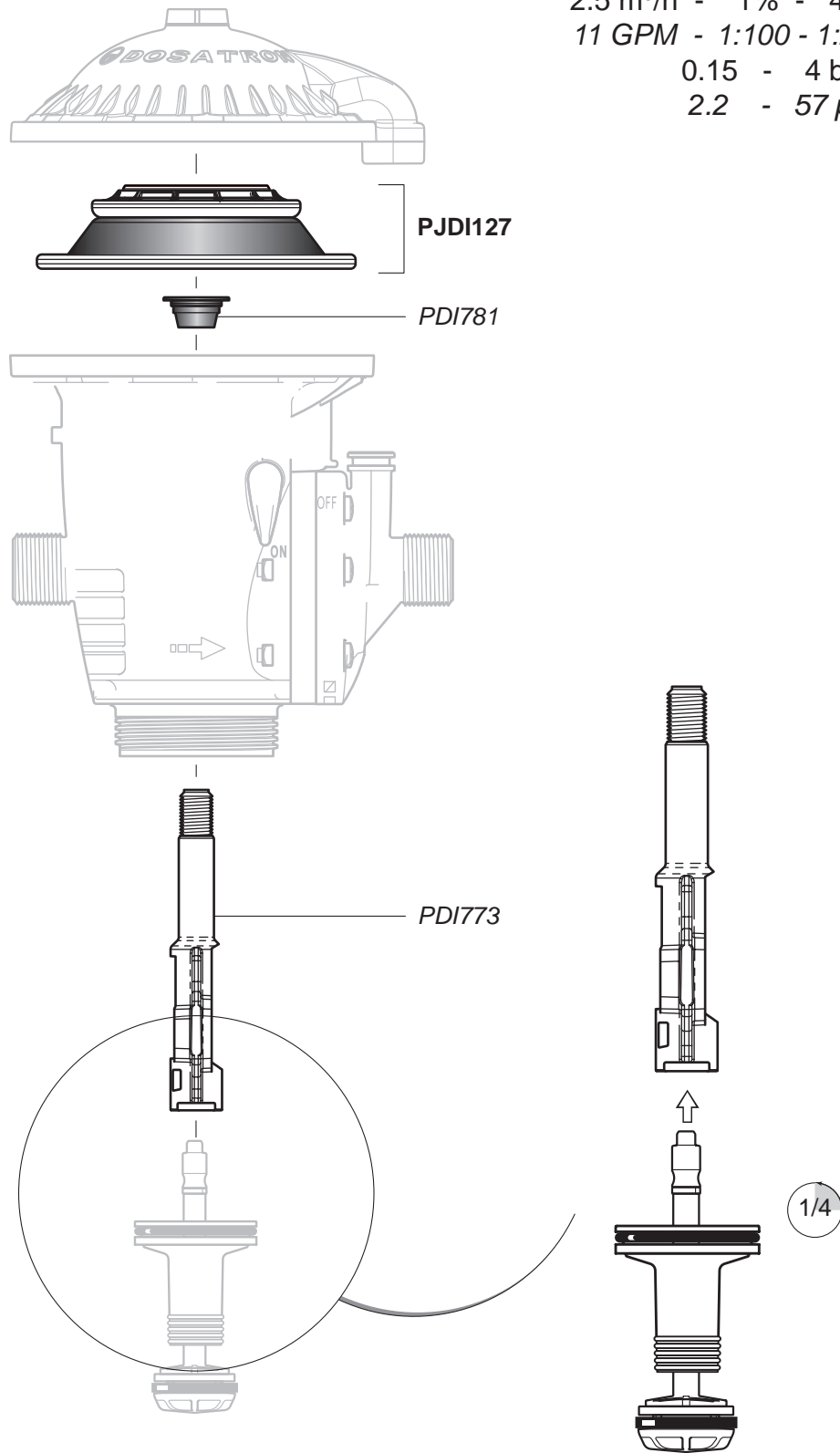

# DIA4RE

2.5 m<sup>3</sup>/h - 1% - 4%  
 11 GPM - 1:100 - 1:25  
 0.15 - 4 bar  
 2.2 - 57 psi

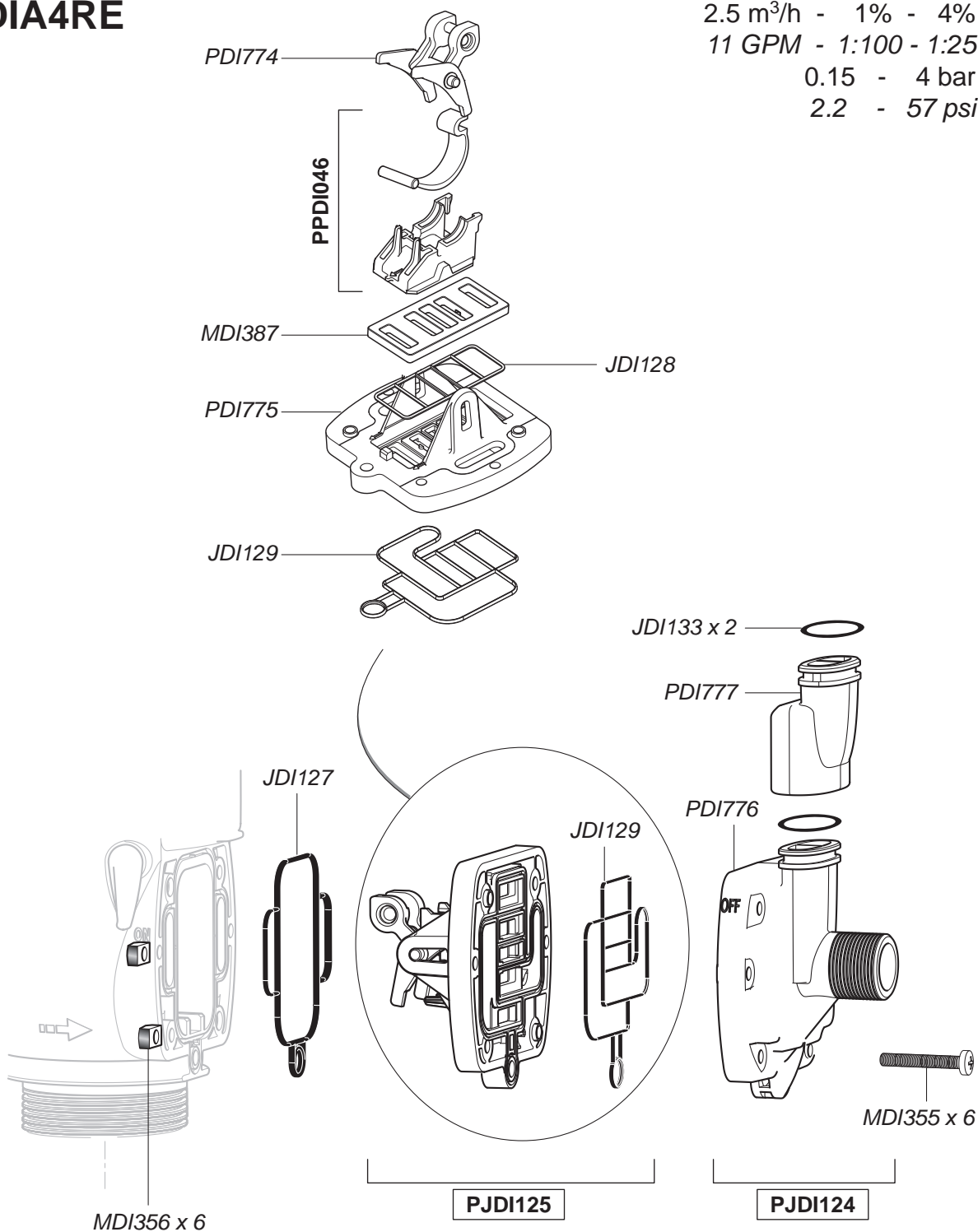

# DIA4RE

2.5 m<sup>3</sup>/h - 1% - 4%  
11 GPM - 1:100 - 1:25  
0.15 - 4 bar  
2.2 - 57 psi

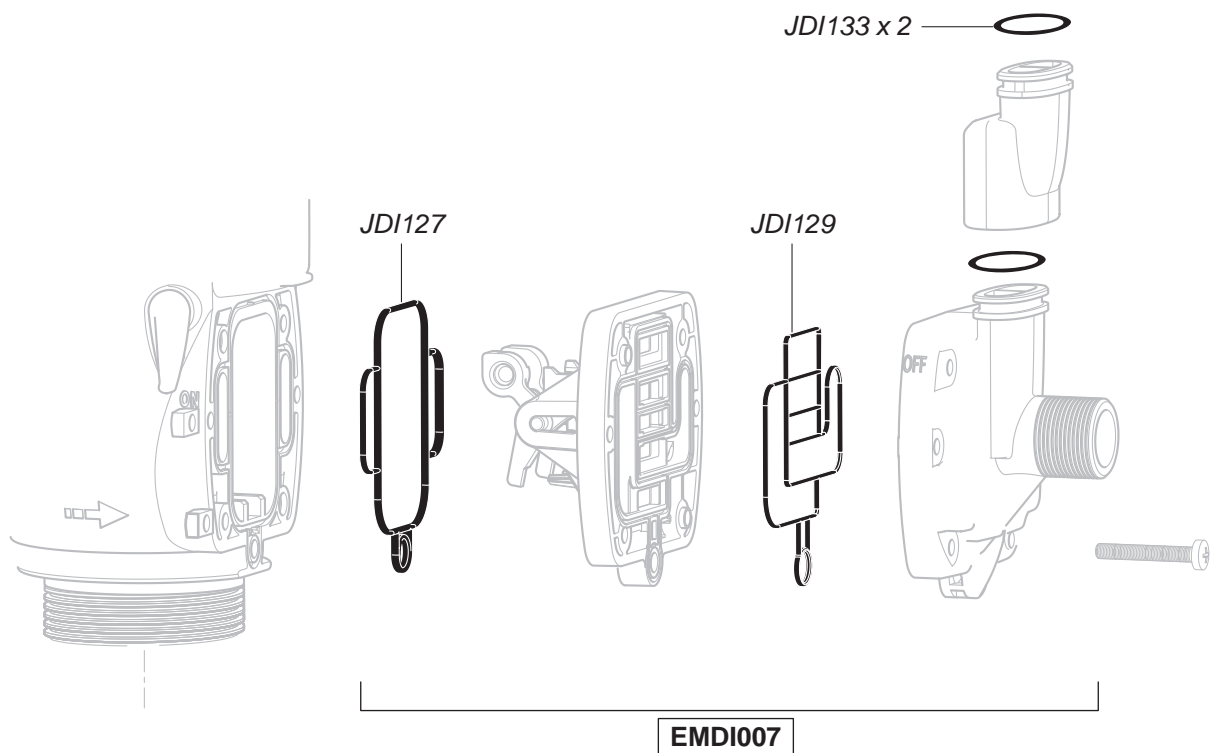

# DIA4RE

2.5 m<sup>3</sup>/h - 1% - 4%  
 11 GPM - 1:100 - 1:25  
 0.15 - 4 bar  
 2.2 - 57 psi

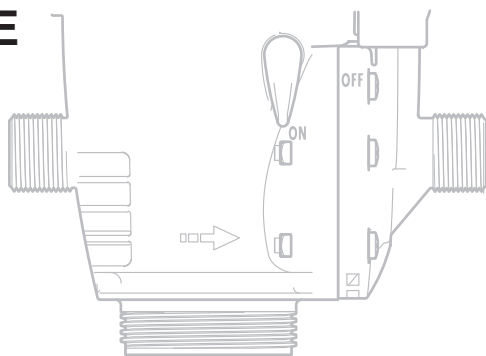

**N° SERIE**  
 ( → N° 1252.... )

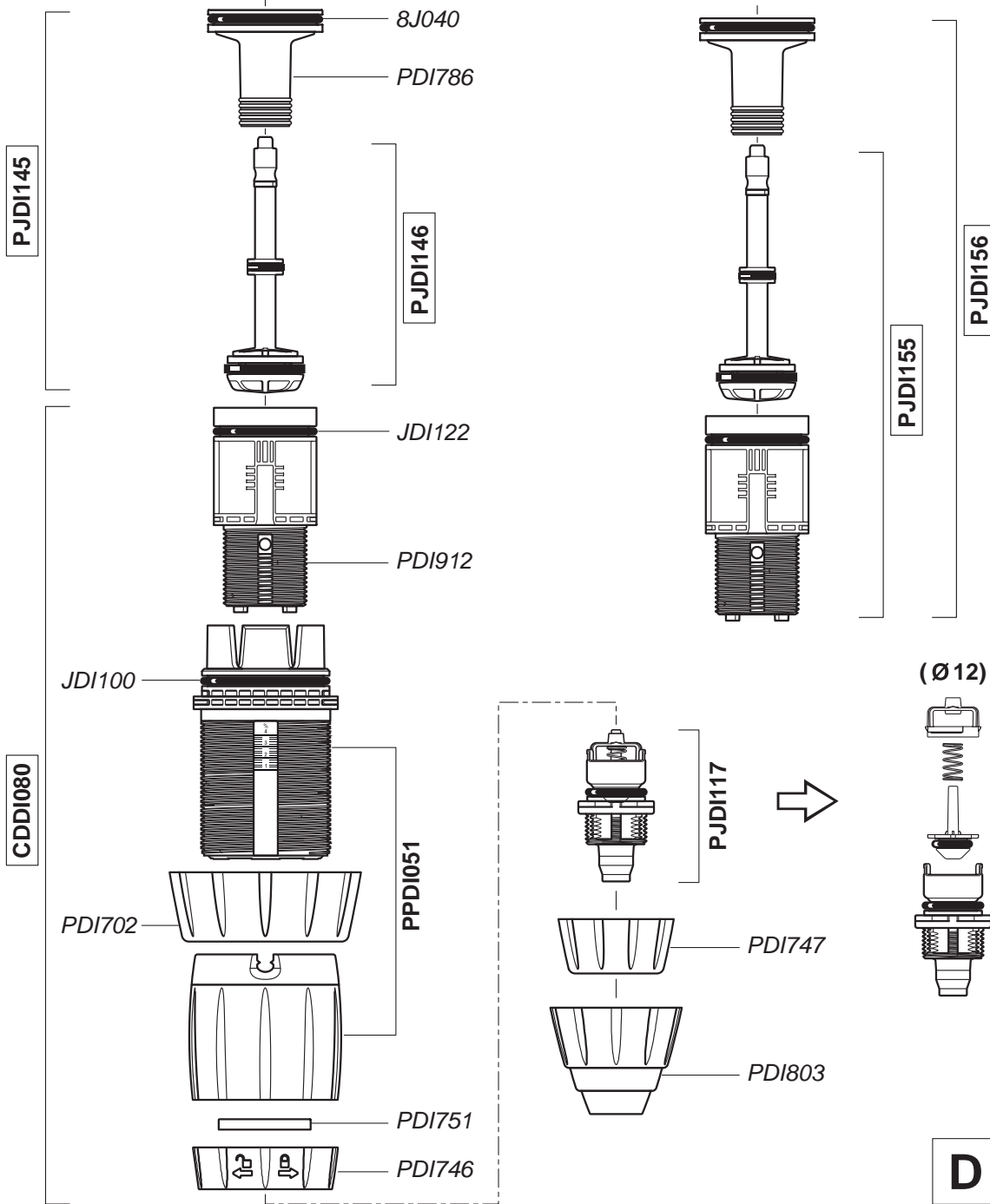



# DIA4RE

2.5 m<sup>3</sup>/h - 1% - 4%  
11 GPM - 1:100 - 1:25  
0.15 - 4 bar  
2.2 - 57 psi

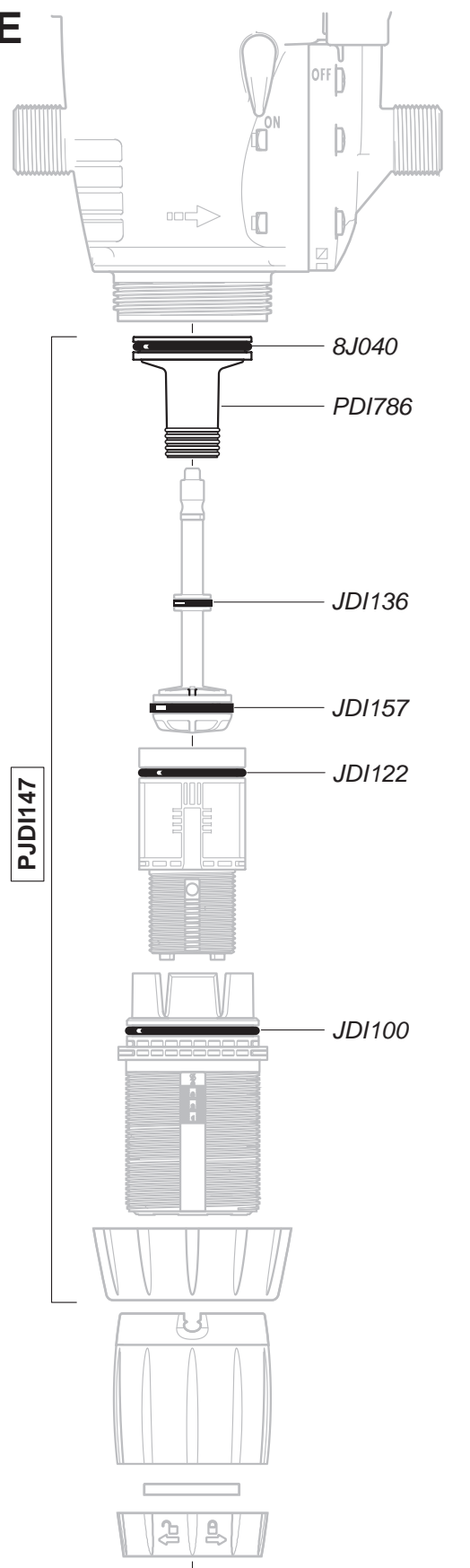

# DIA4RE

2.5 m<sup>3</sup>/h - 1% - 4%  
11 GPM - 1:100 - 1:25  
0.15 - 4 bar  
2.2 - 57 psi

